

Aerosol Drug Delivery:
New Technology for Improved Outcomes

Patrick J. Dunne, MEd, RRT, FAARC
HealthCare Productions, Inc.
Fullerton, CA 92838

Disclosure

**This presentation is sponsored
by
Monaghan Medical**

2015 & Beyond

Time Lines

✧ Spring 2007

- ❖ Task force formed**
- ❖ Health care reform inevitable!**
- ❖ Envision the RT of the future**

✧ 3 invitation-only conference

- ❖ March 2008**
- ❖ Spring 2009**
- ❖ Summer 2010**

2015 Initiative Questions

March 2008 Conference

- ✧ How will the “***new system***” respond to health care needs of patients with acute and chronic respiratory disorders?
- ✧ What current and new capabilities will respiratory therapists need to effectively participate?
- ✧ What additional responsibilities can RTs assume to improve health care outcomes for patients with chronic respiratory diseases?

Second Conference

Spring 2009

- ✧ **Build on proceedings of 1st conference**
 - ❖ **Define knowledge, skills attributes required to competently provide future respiratory services**
 - ❖ **Define the education and credentialing systems required to support future RTs**

Third Conference

Summer 2010

- ✧ Determine how we prepare RTs (***existing and entry-level***) for new roles and responsibilities with minimal impact on the current RT workforce
 - ✧ Getting from ***here*** to ***there***

COPD Symptoms are Treatable

NON-PHARMACOLOGIC

- ✧ Smoking Cessation
- ✧ Pulmonary Rehab
- ✧ LVRS
- ✧ Lung Transplantation
- ✧ Interventional bronchoscopy

PHARMACOLOGIC

- ✧ Beta adrenergics
 - ❖ SABA (*rescue*)
 - ❖ LABA (*maintenance*)
- ✧ Anticholinergics
- ✧ Inhaled corticosteroids
- ✧ Systemic corticosteroids
- ✧ Methylxanthines
- ✧ LTOT

Impact of Smoking Cessation

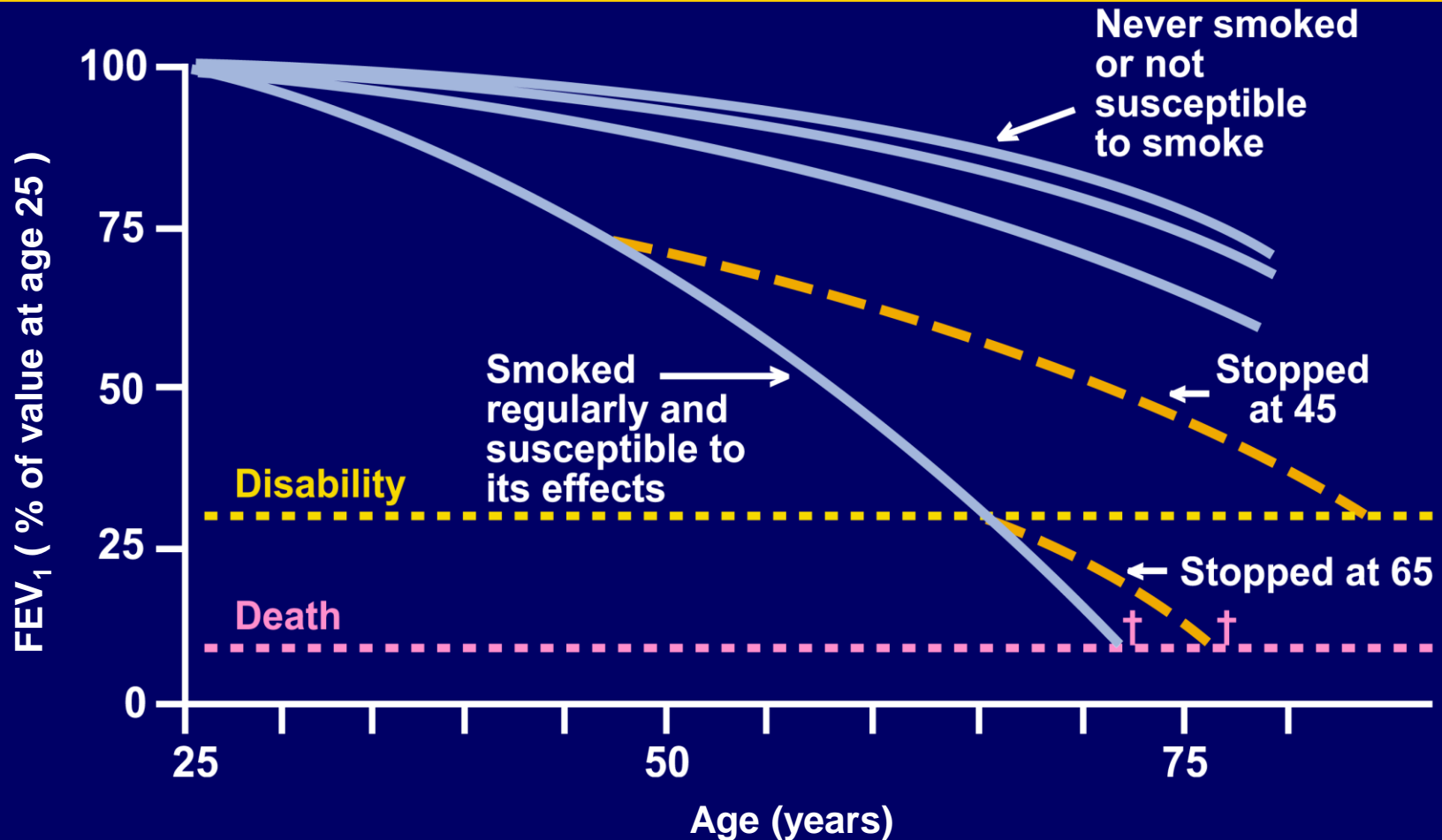

† Death, the underlying cause of which is irreversible chronic obstructive lung disease, whether the immediate cause of death is respiratory failure, pneumonia, cor pulmonale, or aggravation of other heart disease by respiratory insufficiency. Although this shows the rate of loss of FEV₁ for one particular susceptible smoker, other susceptible smokers will have different rates of loss, thus reaching “disability” at different ages.

Adapted from
Anthonisen, *Ann Intern Med*, 2005

Newest Aerosol Drugs for COPD

Advantages of Aerosol Delivery

- ✧ Direct delivery to site of need
- ✧ Quick on-set of action
- ✧ Lower systemic side-effects

In spite of relatively low drug delivery efficiency!

Beta Adrenergics

Quick relief

albuterol

Solution & MDI

levalbuterol

Solution & MDI

Controller

salmeterol

DPI

formoterol

DPI

arformoterol

Solution

formoterol

Solution

Short v/s Long Acting β Agonists

- ✧ **Regular/scheduled use of SABA discouraged**
 - ❖ For *prn* use only
 - ❖ \geq twice/week – symptoms not controlled!
- ✧ **Scheduled, twice daily dosing of a LABA**
 - ❖ A controller medication – 12 hour duration
 - ❖ Available for nebulization; 3-5 min. treatment time
 - ❖ Used In combination with *tiotropium*, *ICS*
 - ❖ Use SABA sparingly for acute episodes

Limitations on Use

- ✧ LABAs are not indicated for rescue therapy
- ✧ LABAs are not indicated for the mono-maintenance treatment of asthma
 - ❖ If used for asthma control, then only in combination with inhaled corticosteroid
 - Advair → *salmeterol & fluticasone (DPI, MDI)*
 - Symbicort → *formoterol & budesonide (MDI)*
 - ❖ FDA alert – exhaust regimen of ICS before combination

Newest in Aerosol Drug Delivery for COPD

Respirable Dose

“The most important characteristic of nebulizer performance is the *respirable dose* provided for the patient.

The *respirable dose* is determined by the mass output of the nebulizer and the size of the droplets that are produced. . .”

Ideal Particle Size

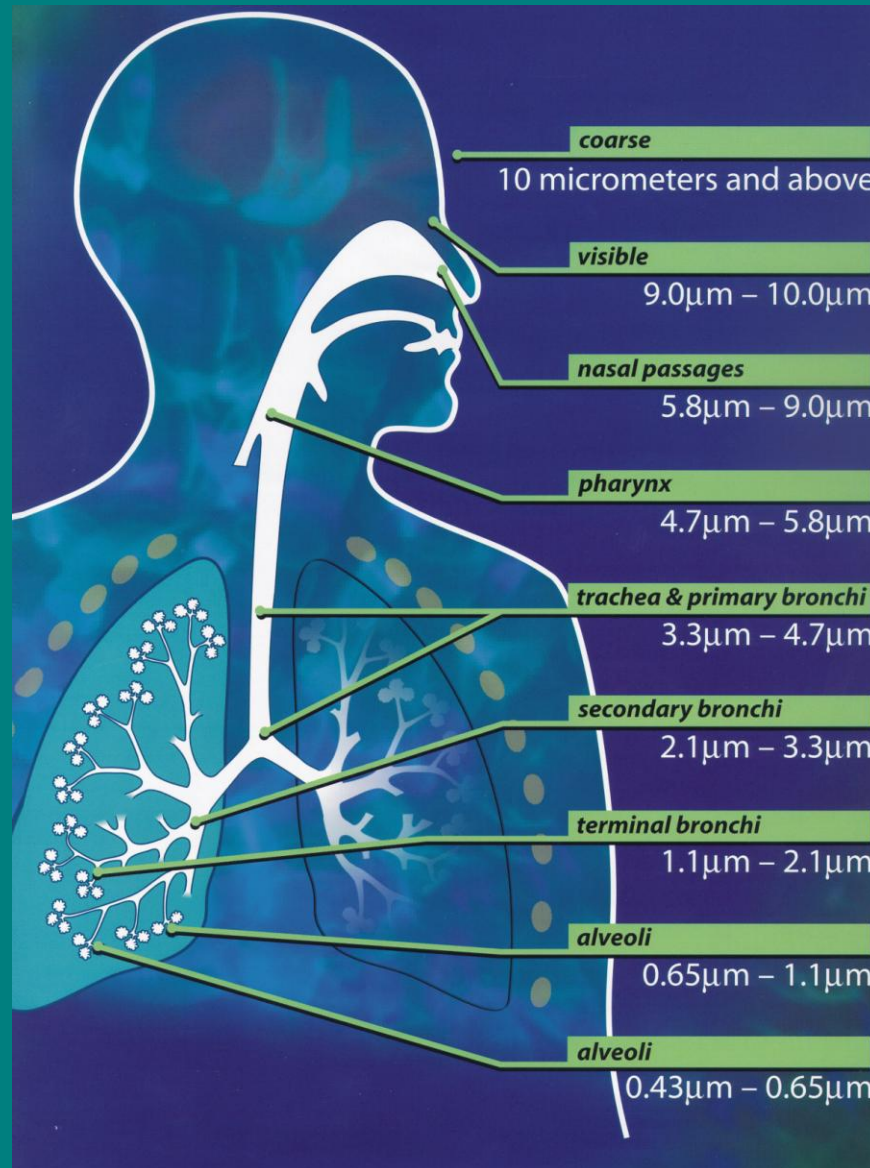

**optimal
airway
deposition**

Performance Comparison of Nebulizer Designs

Rau J, Ari A, Restrepo R. *Respir Care*, February 2004

CONVENTIONAL T-PIECE	BREATH ENHANCED	BREATH ACTUATED
<i>aerosol generated constantly</i>	<i>aerosol generated constantly</i>	<i>aerosol generated inhalation only</i>
<i>co-mingling inhalation & exhalation</i>	<i>no co-mingling inhalation & exhalation</i>	<i>no co-mingling inhalation & exhalation</i>
<i>most ambient loss</i>	<i>less ambient loss</i>	<i>least ambient loss</i>
<i>respirable dose</i> 10 - 15% <i>Least efficient drug delivery</i>	<i>respirable dose</i> 15% - 20% <i>Enhanced drug delivery</i>	<i>respirable dose</i> ≥ 30% <i>2½ times more drug delivery</i>

Constant Output Nebulizers

CONVENTIONAL T-PIECE

Respirable dose: 10 %

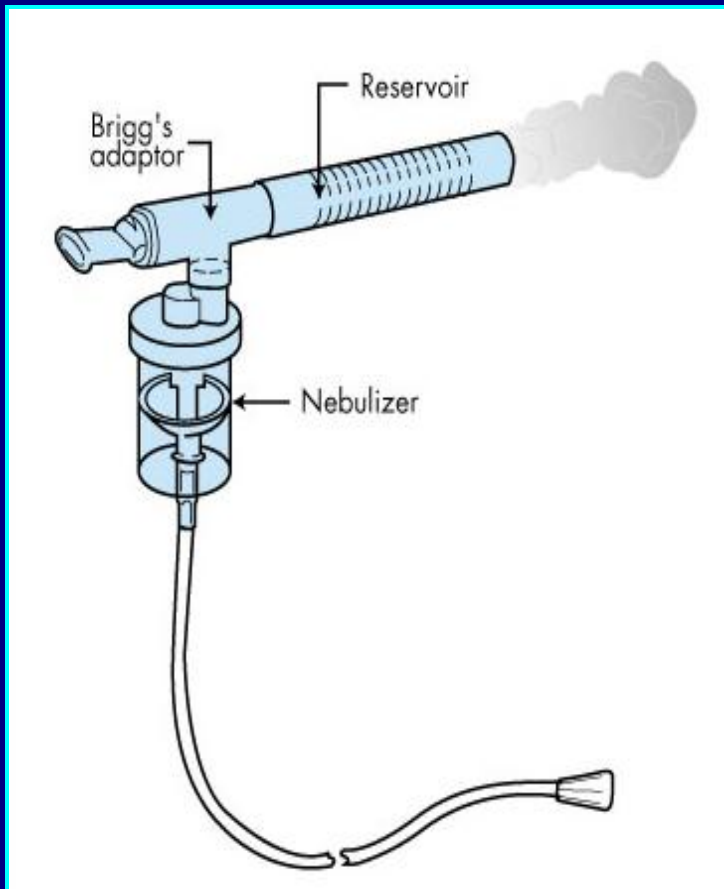

BREATH ENHANCED

Respirable dose: 15%

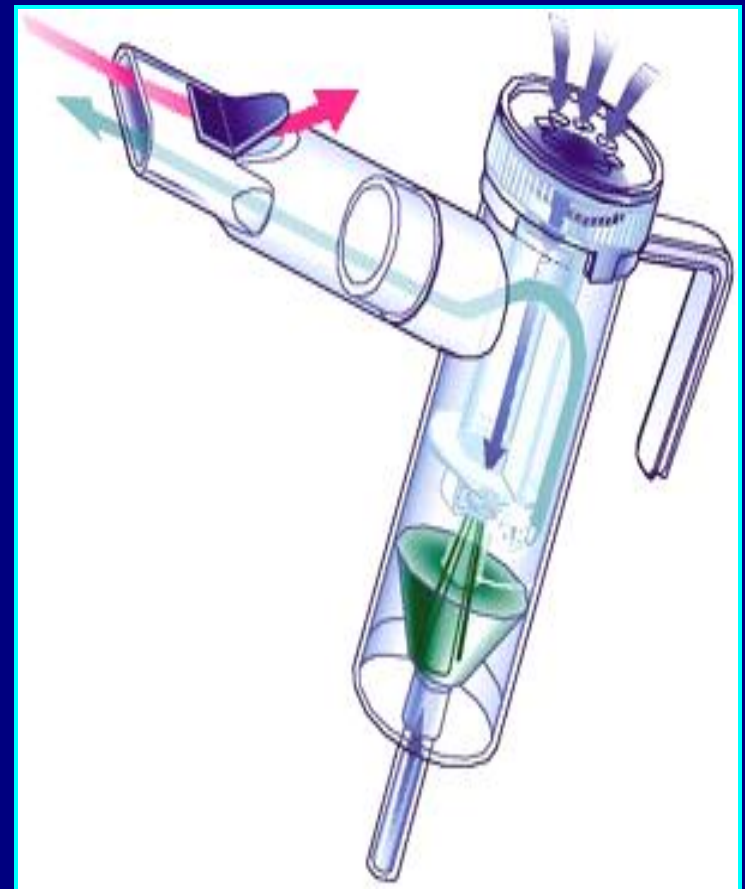

Conventional T-Piece

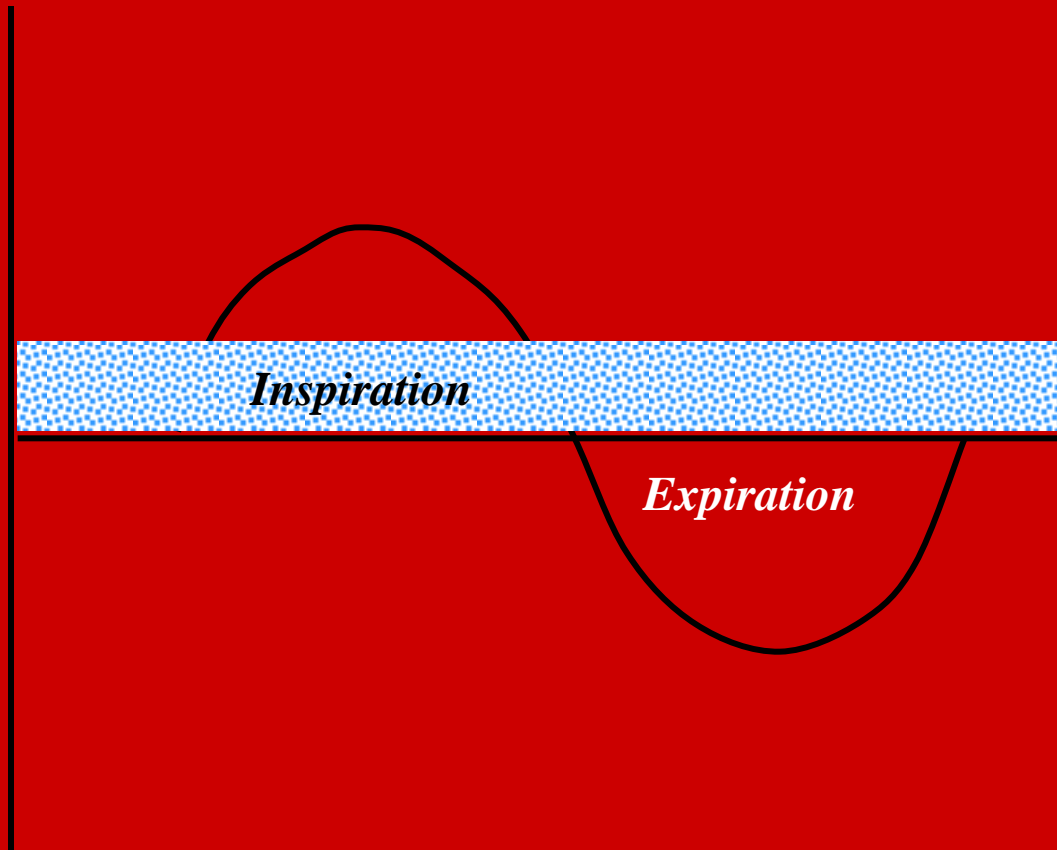

Breath Enhanced

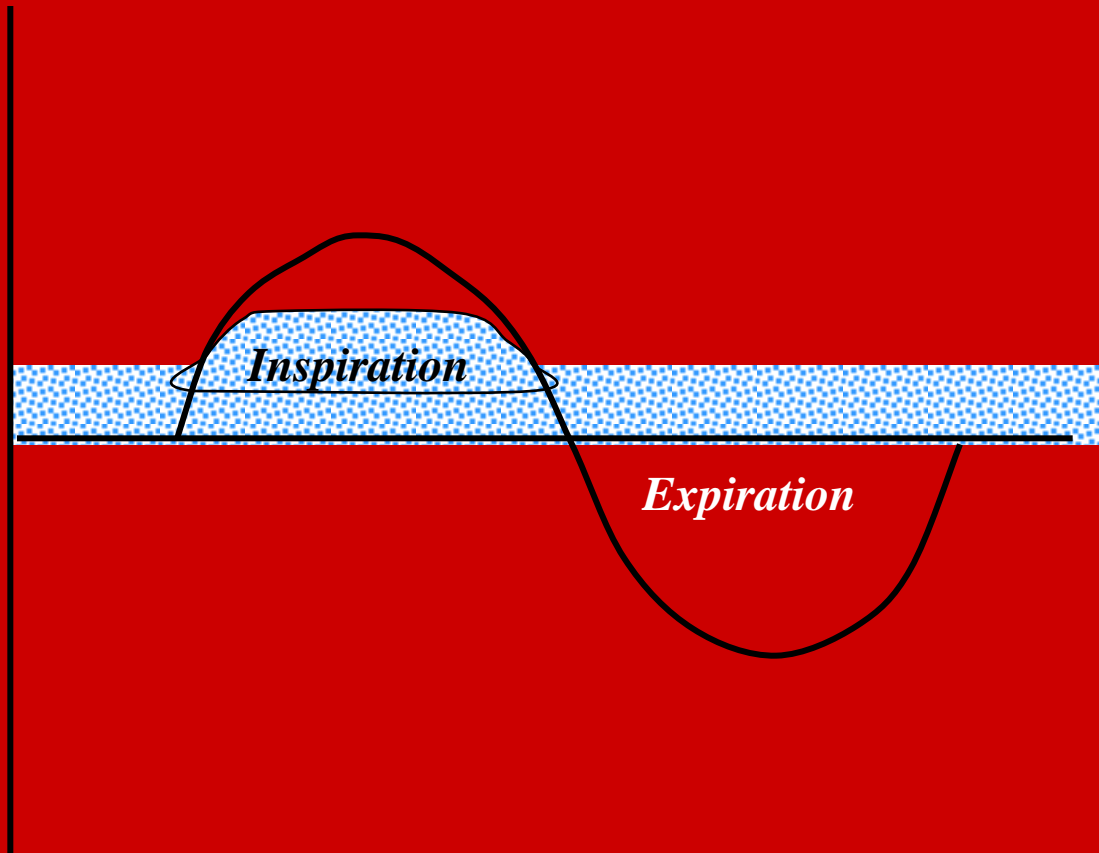

Intermittent Output (Breath Actuated Nebulizer)

ACTUATION INDICATOR

NEBULIZATION ON INHALATION
(or in constant output mode)

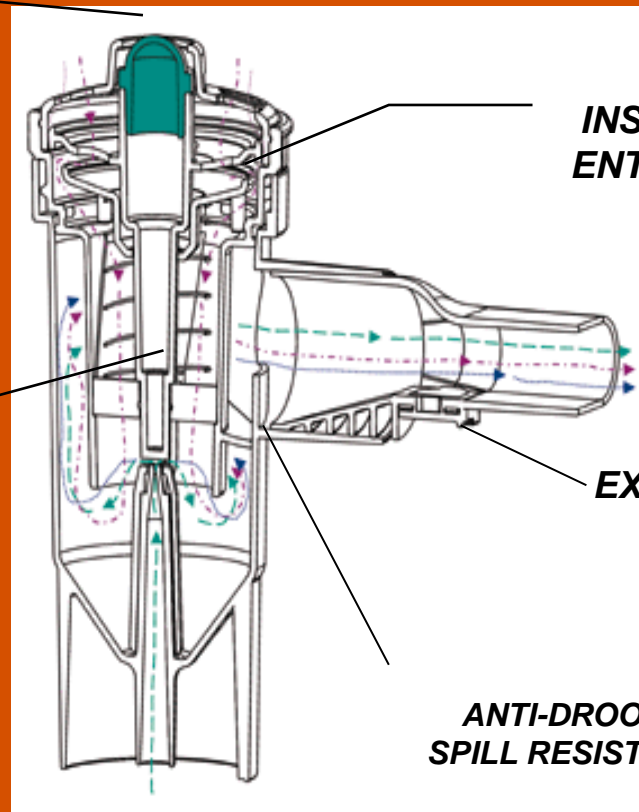

INSPIRATORY
ENTRAINMENT

EXHALATION VALVE

ANTI-DROOL &
SPILL RESISTANT

-  AEROSOL
-  ENTRAINED AIR
-  SUPPLIED GAS

Respirable dose: $\geq 30\%$!

Breath Actuated

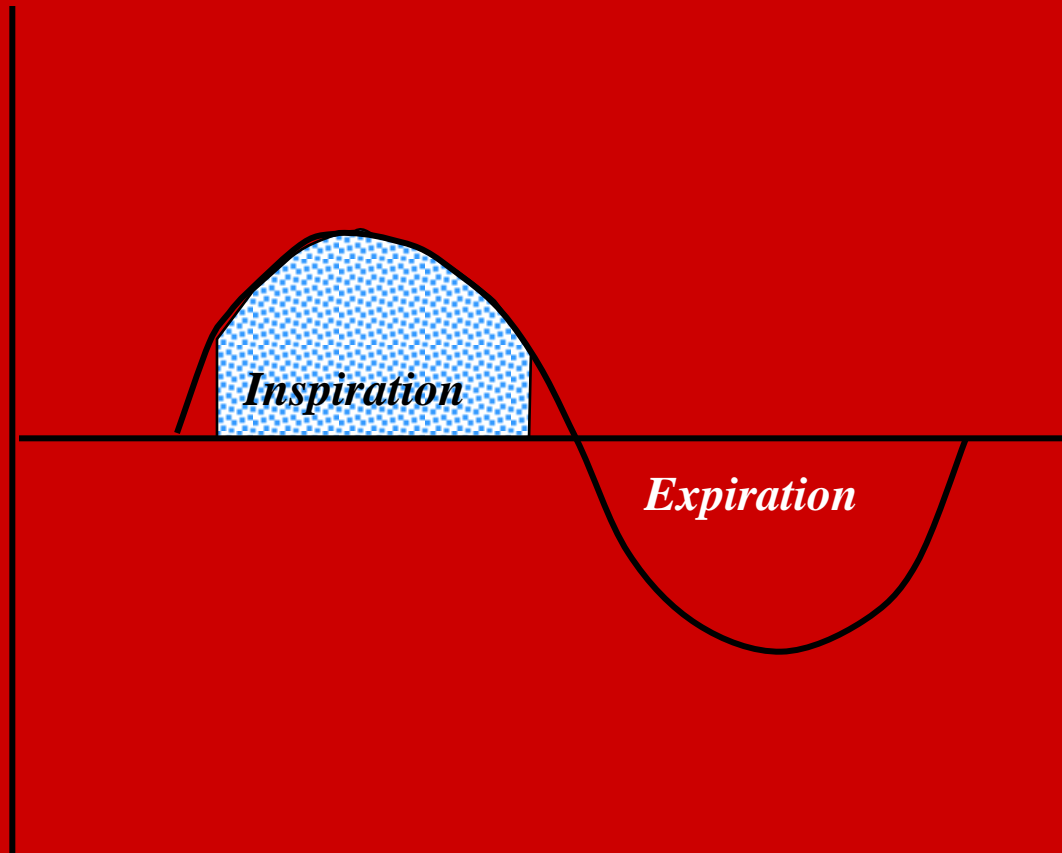

Medication Nebulizers

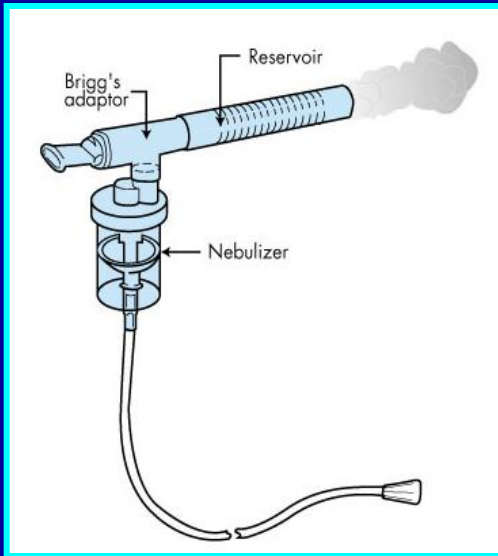

Respirable Dose 10%

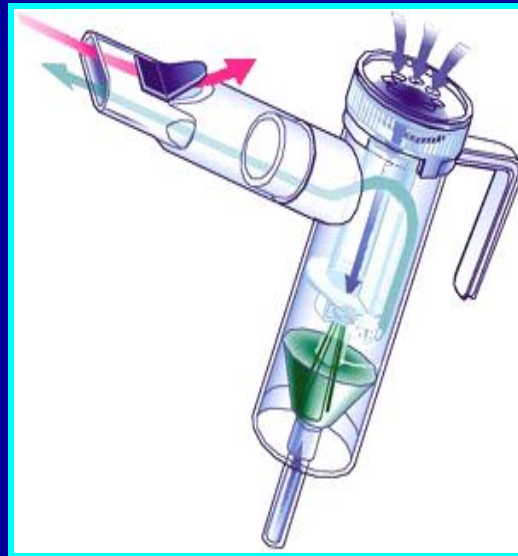

Respirable Dose 15%

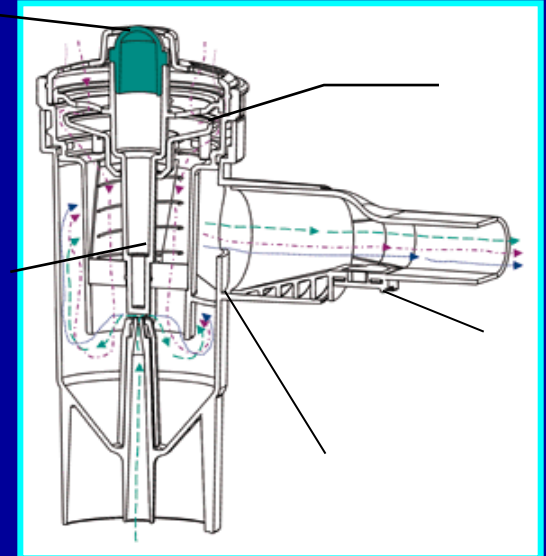

Respirable Dose 30%

Higher respirable dose = quicker onset of action!

Higher respirable dose = shorter treatment times!

pMDI w/ Holding Chamber/Spacer



Issues

High user-error rate

Electrostatic loss w/ HFA

Impact of Inhaler Misuse

Improper handling of inhalers is associated with decreased medicine delivery and poor disease control

Dx of COPD and simultaneous use of multiple inhalers is associated with higher rate of incorrect handling

Patient Instruction for Inhaler Devices

www.chestnet.org

Using your Diskus™

Using your Foradil Aerolizer™

Using your Spiriva Handihaler®

Using your Pulmocort Turbuhaler®

Using your MDI – Open mouth technique

Using your MDI – Closed mouth Technique

Using your MDI with a spacer

Priming and cleaning your MDI

Priming and Cleaning Your MDI and Spacer

Patient Education Guide

AMERICAN COLLEGE OF
CHEST
PHYSICIANS

American College of Chest Physicians
3300 Dundee Road, Northbrook, IL 60062
(847) 498-1400 phone
(847) 498-5460 fax
www.chestnet.org



Priming Your Metered-Dose Inhaler (MDI)

Preparing your MDI will need to be done for every new MDI before it is used or if it has been a long time since you last used your MDI. There are two types of MDIs. You need to ask your health-care provider or pharmacist if your MDI is a HFA or a CFC. The type of MDI you have will dictate how you prepare your MDI before use.

HFA MDIs: If your MDI is new or has not been used in 2 weeks, shake the MDI very well then press down on the MDI four times wasting four puffs into the air. After this is done, you are ready to take your medicine. Follow the instructions below to learn how to take your medicine the correct way.

CFC MDIs: If your MDI is new or has not been used in 12 hours, shake the MDI very well, then press down on the MDI once, wasting one puff of medicine into the air. After this is done, you are ready to take your medicine. Follow the instructions below to learn how to take your medicine the correct way.

Cleaning Your MDI



1 Take metal canister out of plastic container.



2 Rinse plastic container with warm water at least once a week.



3 Let plastic container air dry.



4 Replace metal canister in plastic container.

Cleaning Your Spacer



1 Remove rubber end where MDI fits.



2 Fill a sink or deep bowl with warm water. Add one drop of liquid detergent.



3 Place both pieces in the warm soapy water, and gently shake both pieces back and forth.



4 Rinse only the mouthpiece in running water.



5 Shake to remove the water.



6 Let air dry in vertical position. Do not dry with towels.



7 Put rubber end back on spacer when completely dry.

Anti-Static Holding Chamber



More Time to Breathe Easy.

Introducing – AeroChamber MAX™ with Flow-Vu™ Indicator

Great for children who are ready to change from a mask to a mouthpiece

*Flow-Vu™ Inspiratory Flow Indicator
Indicator moves from vertical position toward patient when patient is inhaling. As patient exhales or stops inhaling, the indicator returns to the vertical position.*

Children are assured the proper dose of medication while learning to coordinate their own treatments.

- Flow-Vu™ Inspiratory Flow Indicator
- FLOWSIGNal® Whistle to assure proper technique
- StatBar™ Custom Anti-static Polymer Chamber
- New Flow Dynamic Valve and Baffle System
- Reinforced Universal pMDI Adapter
- pMDI Adapter Alignment Feature



AeroChamber MAX™
Inspiration pure and simple!

Of course it's from
monaghan.

PARI VORTEX™

NON ELECTROSTATIC VALVED HOLDING CHAMBER



Introducing the new PARI Vortex™ Non-Electrostatic Valved Holding Chamber. It's a revolutionary breakthrough in holding chamber technology.

The non-electrostatic charge of the PARI Vortex ensures that patients receive a more consistent medication dose treatment after treatment, day after day.



COPD Intervention

Disease Management Program for Chronic Obstructive Pulmonary Disease: A Randomized Controlled Trial

Rice KL, et.al. *AJRCCM*; January 2010

- Randomized, adjudicator-blinded, multi-center controlled trial
- 1 year; 5 VA medical centers; 743 subjects with COPD
- Eligibility criteria – within past year, one or more:
 - Hospitalization (or) ED visit for COPD
 - Chronic home oxygen use for COPD
 - Course of systemic corticosteroids for COPD
- Compare intervention (*n=372*) to control group (*n=371*)
- Baseline characteristics well-matched
 - Predominately males (*98%*); Severe disease ($FEV_1 \leq 37\%$)
 - 55% on LTOT; 22% current smokers

COPD Intervention

Rice KL, et.al. AJRCCM; January 2010

- **Control/usual care:**
 - Single page handout on COPD care
 - Telephone # of 24-hour VA nursing helpline
- **Intervention by *case manager*:**
 - 1 – 1.5 hour education session on COPD
 - Action plan for self-treatment of exacerbations
 - Monthly follow-up phone calls; Daytime helpline
- **Primary outcome:**
 - Combined # of COPD-related hospitalizations/ED visits
- **Secondary outcomes:**
 - Hospitalizations/ED visits for ALL causes
 - Respiratory medication use
 - Mortality; Change in SGRQ

COPD Intervention

Rice KL, et.al. AJRCCM; January 2010

- **Patient education session:**
 - **General information about COPD**
 - **Observation/retraining in correct inhaler use**
 - **Review/adjust all medications**
 - **Tobacco cessation counseling**
 - **Advise on influenza/pneumococcal vaccination**
 - **Encouragement of regular exercise**
 - **Basic hand hygiene**
- **Patient action plan**
 - **Increase in sputum volume +/- or change in color**
 - **Increase in dyspnea**

Patient Action Plan

1113074552

Lung Disease Management Clinical Study
PATIENT ACTION PLAN

Patient ID

Patient Initials _____
(Please Print)

VA Site: Des Moines Iowa City Minneapolis Omaha Sioux Falls

Patients who suffer from lung problems have a greater chance of developing breathing problems from a respiratory infection.

Watch for the following signs and symptoms:

- Significant increase in sputum volume
- Change in the color of your sputum from clear to yellow / green / brown / tan

If you develop either of the above symptoms, please follow this medication plan:

Antibiotic: _____ Dosage: _____

Frequency: _____ For _____ Days

If you have a significant increase in your shortness of breath, especially if it is not relieved by your inhalers, take Prednisone:

40 mg a day for 10 days

OR

40 mg for 2 days, then 30 mg for 2 days, then 20 mg for 2 days, then 10 mg for 2 days, then 5 mg for 2 days, then stop

Please call the Lung Disease Management *Case Manager* if you start Antibiotics or Prednisone

Case Manager: _____

Monday - Friday at: (____) _____

Always keep a refill of each prescription on hand.

24-hour, toll-free PRESCRIPTION REFILL phone number: 1-800-661-0827

24-hour, toll-free VA NURSE Telephone advice line: 1-866-687-7382

Page 1 of 1

COPD Intervention

Rice KL, et.al. AJRCCM; January 2010

- **Conclusions:**
 - “A relatively simple disease management program reduced hospitalizations and ED visits for COPD . . . Although a formal cost benefit analysis has not been done, this intervention shows potential for reducing health care costs in addition to increasing quality”
- **The case manager was a RESPIRATORY THERAPIST!**

A GUIDE TO
Aerosol Delivery Devices

FOR *Respiratory
Therapists*

Dean R Hess PhD RRT FAARC

Timothy R Myers BS RRT-NPS

Joseph L Rau PhD RRT FAARC

With a Foreword by

Sam Giordano, Executive Director

American Association for Respiratory Care



Produced in collaboration with the
American Association for Respiratory Care

Supported by an educational grant
from Respironics, Inc.

RESPIRONICS

www.AARC.org

**Four (4) units of
continuing
respiratory care
education (CRCE)**



Proceedings from a special symposium on

*Improving Symptom Control in Patients
with Chronic Respiratory Disease*

Presented at the 54th International Respiratory Congress of the
American Association for Respiratory Care
December 2008 • Anaheim, California

Supported by an unrestricted educational grant from



www.AARC.org

***Four (4) units of
continuing
respiratory care
education (CRCE)***

To Sum Up

- ✧ COPD affects millions and costs billions!
- ✧ Newer advances in COPD treatment options (*and coverage*) will continually improve clinical outcomes
- ✧ Newest GOLD (*and NAEPP*) Guidelines de-emphasize the daily scheduled use of SABAs
- ✧ Reduced number of scheduled daily treatments and reduced time per treatment has the potential to substantially improve sustained adherence

Aerosol Drug Delivery:
New Technology for Improved Outcomes

Patrick J. Dunne, MEd, RRT, FAARC
HealthCare Productions, Inc.
Fullerton, CA 92838